

**IMPORTANT NOTES:**

**1. DC SELECTION FOR PROTECTION SYSTEM**

DC SELECTION FOR PROTECTION SYSTEM	
PANEL DC-1	DIFFERENTIAL, HV OCDEF, IV BACKUP IMP, BB PU-A(>400kV), TC-1
PANEL DC-2	REF, IV OCDEF, HV BACKUP IMP, BB PU-B(>400kV), TC-2
BUSBAR DC-1	BB CU-A(>400kV)
BUSBAR DC-2	BB CU-B(>400kV)
SELECTED DC	CB CLOSE, BCU, STAND ALONE LBB, FOR SINGLE BUSBAR RELAY-CU & PU(<220kV), VT SELECTION, CT SELECTION

- FOR CENTRALISED BUSBAR PROTECTION 96 TRIP RELAY SHOULD BE PROVIDED.
- IN THE SCHEME, CMR(CONTACT MULTIPLICATION RELAY) MUST NOT BE USED EXCEPT FOR TRIP EXTENSION TO CIRCUIT BREAKER.
- RETRIP SHOULD BE EXTENDED TO TC-1 & TC-2 COIL THROUGH DIRECT CONTACT OF PU-A & PU-B IN DECENTRALISED BUSBAR SCHEME AND THROUGH STANDALONE LBB IN CENTRALISED BUSBAR SCHEME.
- ALL THE TRIPPING CIRCUIT SHOULD BE ISOLATED BY TEST PLUG CONTACT.
- IN CASE OF FUTURE BAY(WITHOUT CT & CB), THE CB LBB BACKTRIP & THE CT CORE HAS TO BE EXTENDED TO BUSBAR WITH FUTURE BAY. ALSO BUSBAR TRIP(FUTURE BAY SIDE) TO BE EXTENDED TO THE CB OF HALF DIA.
- IN CASE OF FUTURE BAY(WITH CT & CB), THE CT CORE HAS TO BE EXTENDED TO BUSBAR WITH FUTURE BAY. IN ADDITION TO THIS, THE BAY LBB BACKTRIP ASSIGNMENT HAS TO BE IMPLEMENTED AS PER COMPLETE DIA SPECIFIC SCHEME. ALSO BUSBAR TRIP(FUTURE BAY SIDE) TO BE EXTENDED TO THE & MAIN CB(FUTURE BAY).
- IF DOUBLE BUCHHOLZ RELAYS AVAILABLE, THEN BUCHHOLZ ALARM SHOULD NOT BE EXTENDED TO TRIP.
- PRV OF OLTC & SPR PROTECTION OF ICT(MAIN TANK AS WELL AS OLTC) SHALL BE CONFIGURED AS ALARM ONLY AND SHALL NOT INITIATE ANY TRIPPING.
- MINIMUM BREAKER CLOSING TIME - 200ms, MINIMUM TRIPPING TIME - 100ms.

**Transformer Body Protection Logic**

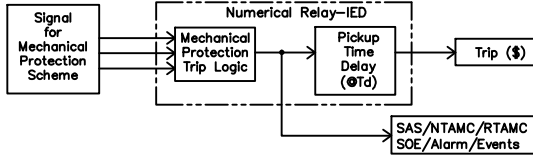

**Note:**

- Td = 200ms -> For Buchholz Alarm
- = 200ms -> For Buchholz Trip
- = 20ms -> For Other Body Protection Schemes as applicable

Trip (\$) = Final Mechanical Tripping to Master trip(86A & B) as per Trip matrix  
NOTE: FINAL TRIP OUTPUT NEED TO BE CONFIGURED FOR RELAY INTERNAL EVENTS

**A. WTI/OTI Protection Logic**

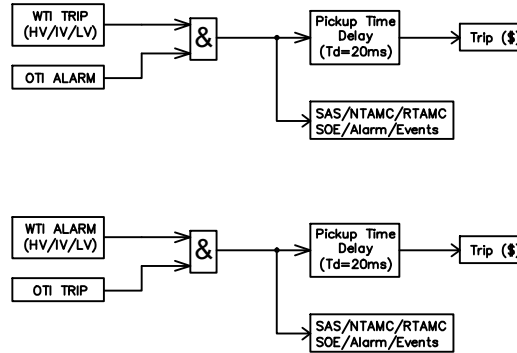

**B. PRV of Main Tank Protection Logic**

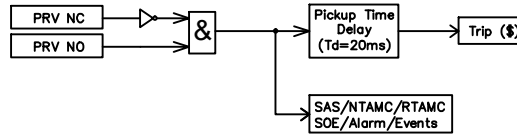

**C. OSR Protection Logic**

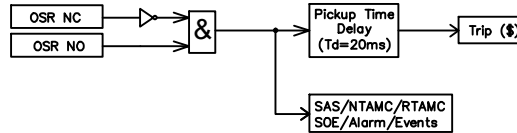

**INDICATIVE CB CLOSE SOFTWARE INTERLOCK LOGIC IN BCU**

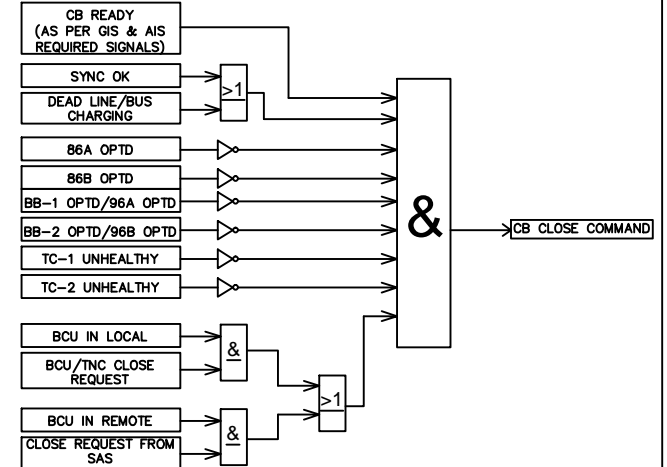

**INDICATIVE CB HARDWARE INTERLOCK LOGIC IN CRP**

